

| Load Class | A 15 | B 125 | C 250 | D 400* |
|-----------------|------|--|-------|---------|
| Minimum | X | 150 | 150 | 150 |
| Dimensions (mm) | Y | Full Channel Height (Less Y2 where applicable) | | |
| | Z | 150 | 150 | 150 |
| Maximum | **Y2 | 35 | 35 | 35 |
| | **Y3 | 60 | 60 | 60 |
| | Y4 | No front haunch | | Max 100 |

** Where regular HGV impacts are anticipated (e.g. roundabouts), we recommend that the concrete backing is laid to the top of the ACO KerbDrain unit (i.e. Y2 = 0, Y3 = 0).

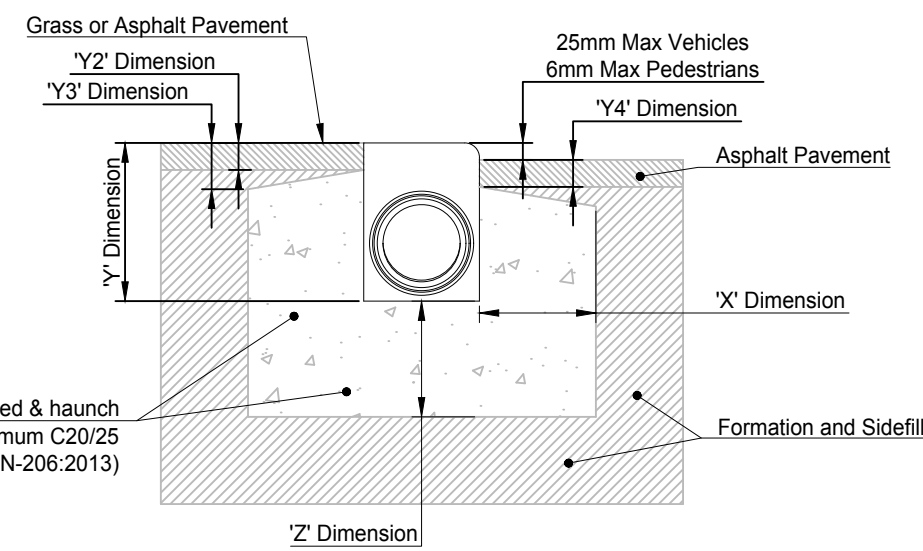

1 : 10 ACO KerbDrain KDHB Grass or Asphalt Pavement

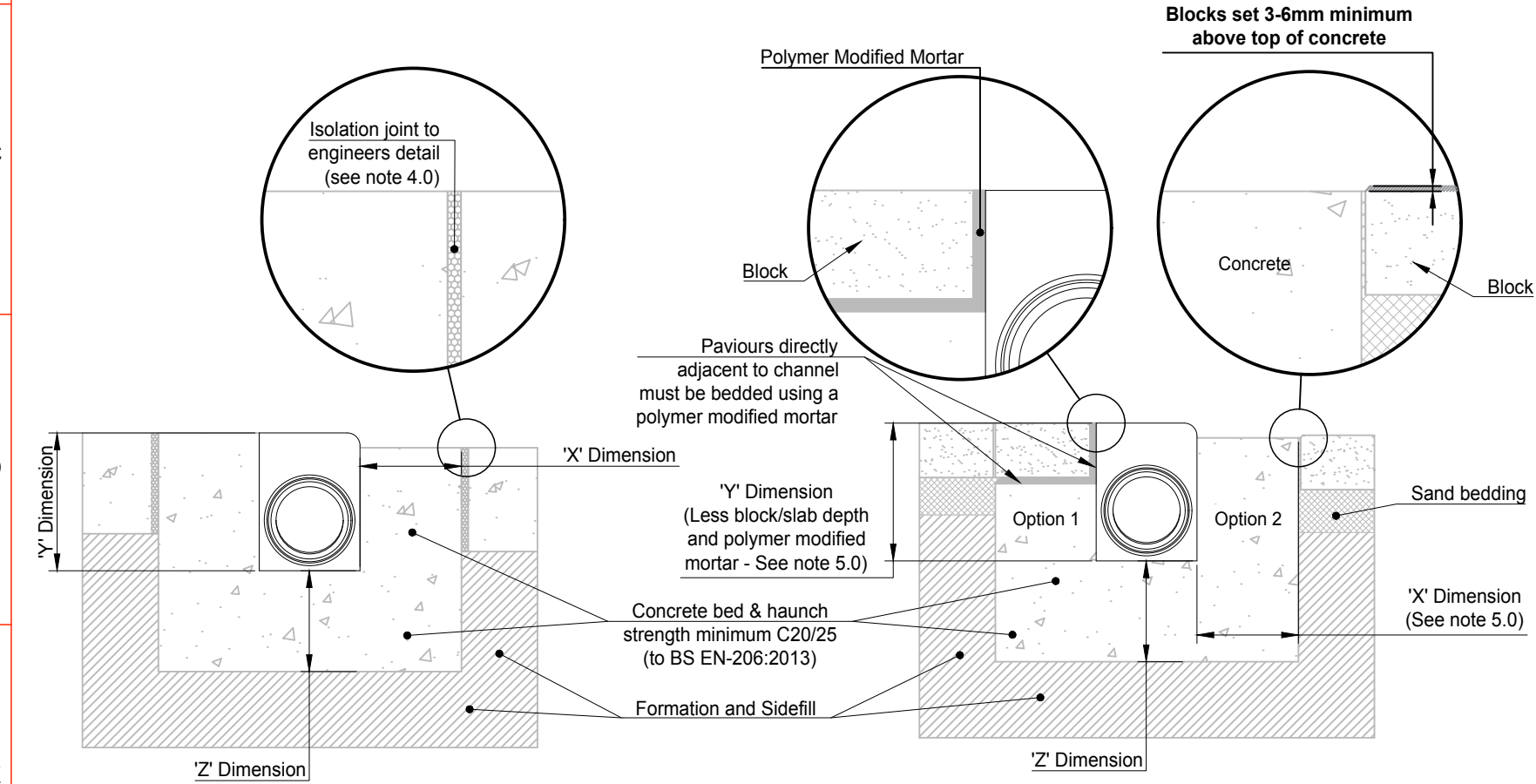

1 : 10 ACO KerbDrain KDHB Concrete Pavement

1 : 10 ACO KerbDrain KDHB Block Pavement (Option 1 and 2)

1.0 Load Class
Installation recommendations shown are ACO minimum recommendations for BS EN 1433:2002 load class requirements.

2.0 Ground Conditions
The long term performance of a channel installation to sustain vertical and lateral loads depends upon A) ground conditions B) stability of the adjacent pavement and C) a durable concrete bed and surround. The recommended installation detail may require the minimum dimensions to be revised to achieve site specific load class requirements (referred to in 1.0 above).

3.0 Cutting and Jointing
Mitre joints are formed by cutting the channels to the required angle and butting them together with appropriate sealant (e.g. Sikaflex 11FC or similar) or ACO Repair Kit. Angles can be formed using radius or mitre units or by connecting them using proprietary PVCu pipework attached to ACO inlet/outlet endcaps. For further details please contact ACO Design Services Team.
Note: Where requested ACO can custom manufacture angled units to order.

4.0 Isolation Joints
The channel must be isolated from the surrounding environment. An isolation joint must be positioned up to 1500mm from the channel wall. Any dowel bars must be located no nearer than 150mm from the channel wall. Other isolation joints in surrounding slab must be continued through the channel. Additional crack control may be required to comply with specifier requirements.

5.0 Block Pavements
The channel must be supported laterally. Blocks laid directly against a channel must be laid as a soldier course and restrained from movement by bedding securely on the concrete haunch e.g. by using a polymer modified mortar for bed and perpendicular joints (e.g. RONAFIX mortar mix C or similar). Alternatively, extend concrete haunch up to finished paving level (as depicted in Option 2). Blocks or slabs bedded on sand remote from the channel should be set at a higher level to compensate for possible settlement of the paving in service.

6.0 Watertight Installation to BS EN 1433:2002
Where ACO channel joints/fittings and channel/pavement interfaces are to be sealed, an appropriate sealant should be used (e.g. Sikaflex 11FC or similar). Guidance on the necessary surface preparation and/or priming should be sought from the sealant manufacturer.

- For Guidance a typical method of application follows:**
- The end faces of the channels are to be sound and free from dust, oil, and grease, with any loose material or dirt removed, e.g. by mechanical wire brush. No water drops should be evident.
 - Using a standard cartridge gun, apply the sealant evenly and with no flaws. The detail on the ends of a channel varies from one product to another:
 - Products with a basically flat face - apply the sealant in a layer approximately 5mm thick to one face of the joint.
 - Products with a sealing groove within the end face - apply the sealant in a bead of approximately 10mm diameter into the sealing groove.
 - Products with a sealing groove following the inside shape of the channel - apply the sealant to the end face of the channel and to the sealant groove, such that when the joint is completed, the sealant will both cover the end face and fill the groove.
 - The channel unit should be placed on the prepared concrete bedding and pressed against the previously placed channel unit. A sealed joint of approximately 1-2mm width should be formed between adjacent channel units.
 - Excess sealant should be wiped from the inside face of the channel to leave a smooth finish.
 - The sealant is to be left to cure for 24 hours, during which time the sealant should be kept as dry as possible.

Highways Specification - Appendix 5/5:
The Appendix 5/5 will need to be completed for each project. A model Appendix 5/5 for ACO KerbDrain® is available from the ACO Water Management Design Services Team.

NBS Specification:
ACO KerbDrain® should be specified in section Q10:190. Assistance in completing this clause can be found in ACO Technologies product entries in NBS Plus or a model specification can be downloaded from www.aco.co.uk. For further assistance, contact the ACO Water Management Design services Team.

Best Practice and Workmanship:
ACO can give guidance with respect to the most suitable methods of installation for each of the products in the ACO KerbDrain® range. ACO KerbDrain® should be installed using acceptable levels of workmanship according to the National Code of Practice (UK: BS8000-0:2014) in keeping with EN 1433:2002 (Drainage channels for vehicular and pedestrian areas).

Detailed installation statements and methodologies will vary for all sites as each will have different aspects deserving particular consideration, consequently the relevant approvals should be sought from the consulting engineer and/or the installer.

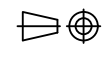
| | | | |
|---|------------------------|---|---------------|
| C | 28.6.2016 | Updated title block | TS |
| B | 1.6.2016 | Revised to comments 12/04/16 | TS |
| Version | Date | Description | Name |
|  | | Drawing Number: 21941 | Revision: C |
| ACO Business Park Hitchin Road Shefford Bedfordshire SG17 5TE, UK Tel: 01462 816666 www.aco.co.uk | | ACO KERBDRAIN KDHB305 CENTRE STONE INSTALLATION DETAIL DRAWING | |
| Created by: IM | Released by: TS | Projection: ISO-A  | Units: mm |
| Created at: 11.1.2016 | Released at: 28.6.2016 | | Format: A3 |
| Replacement for: E1-E01-010-3 | Replaced by: | Information contained in this drawing is copyright property of ACO Technologies plc. Any reproduction in part or whole without written permission of ACO Technologies plc is prohibited | Scale: 1 : 10 |
| | | | Sheet: 1 of 1 |