

Installation manual

ACO Sludge Trap G-H

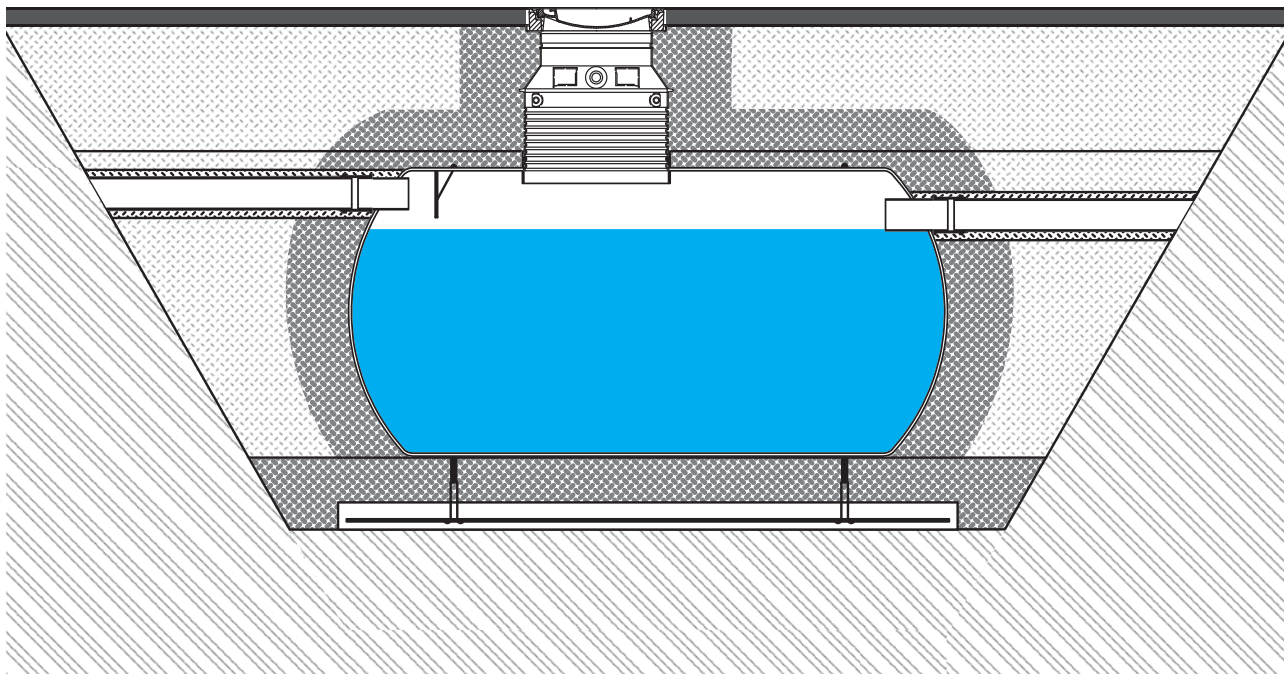

CONTENT



CONTENT	2
STRUCTURE AND COMPONENTS	3
INSTALLATION IN GENERAL	4
Application	
Proper use includes	
Staff	
Journal	
Technical Amendments	
Product Description	
Function	
Flexible application	
STRUCTURE - A 15/B 125/D 400	5
DIMENSIONS - A 15/B 125/D 400	6
LEGEND	7
TANK INSTALLATION	7
TOP SECTION INSTALLATION	10
ALARM CONNECTION	12
TOP SECTION INSTALLATION FOR LOAD CLASS - A 15/B 125/D 400	12
DESIGNATION LABEL	16
NOTES	17

Note:

Read this manual before installing the Sludge Trap G-H. This manual is for the ACO prefabricated Sludge Trap G-H.

This manual should be used when installing the Sludge Trap G-H. This manual should be kept available at the workplace / installation site. Installation of the Sludge Trap G-H must be performed by qualified installers.

Provisions under applicable laws should be followed in order to prevent accidents and protect the environment.

Terms and Conditions:

Any change or alteration made to the Sludge Trap G-H by the consumer without ACO's specific approval will void all warranty obligations.

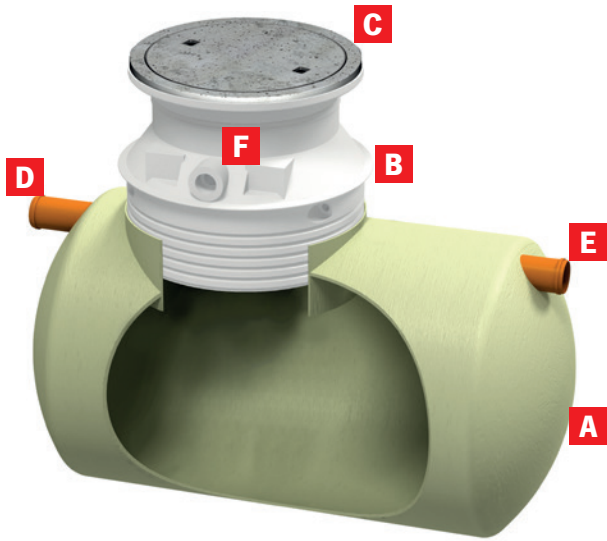

STRUCTURES AND COMPONENTS

**ACO Sludge Trap G-H
A 15**

- A Grease Separator (bottom part)
- B Extension shaft
- C ACO Cover A 15
- D Inlet
- E Outlet
- F Slot for alarm connection (optional)

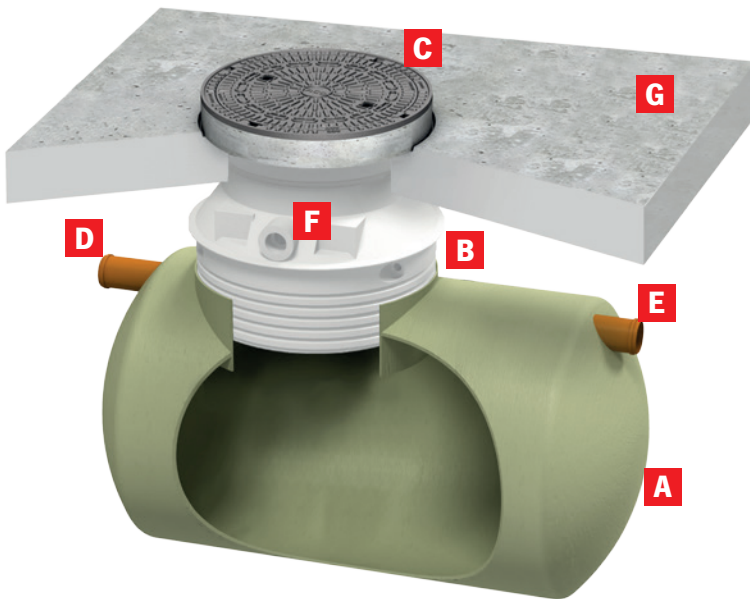
**ACO Sludge Trap G-H
B 125 / D 400**

- A Grease Separator (bottom part)
- B Extension shaft
- C ACO Cover B 125 / D 400 and load protection slab
- D Inlet
- E Outlet
- F Slot for alarm connection (optional)
- G Concrete load distribution plate

INSTALLATION IN GENERAL

Application

The Sand Trap G-H is a tank designed for the removal of gravel and silt from stormwater and wastewater. Wastewater, for example, comes from the car wash, garage, parking areas or industries.

The manufacturer is not liable for any damages caused by misuse. Responsibility falls entirely on the operator.

Terms and Conditions:

- Compliance with national laws and regulations;
- Compliance with all inspection and service instructions;
- Adhere to the manufacturer's installation, operation and maintenance instructions.

Staff

Personnel who perform the installation, operation, maintenance and servicing of this sludge separator must possess the training needed to do these tasks and must understand the contents of this manual.

Journal

A record shall be established and include the following:

- Checks carried out by operational staff;
- Service and test reports;
- Any breakdowns and repairs.

Technical Amendments

ACO reserves the right to make ongoing technical modifications which may result in differences between published text and/or images, and the product.

Product Description

The Sand Trap G-H gravel and silt separator is designed for installation in the ground. The separator comes with inlet and outlet connections, an extension neck made of PE-HD.

Function

Sand Trap G works on the gravimetric principle. Sludge and heavier particles fall to the bottom. The treated water flows out through the outlet.

Flexible application

(according to EN 124)

- **Load class A 15**
Footways and areas accessible only to pedestrian & pedal cyclists
- **Load class B 125**
Footways that can be mounted by vehicle or livestock, and light tractor paths
- **Load class D 400**
Carriageways of roads and areas open to commercial vehicles

Load classes



A 15



B 125



D 400

STRUCTURE - A 15

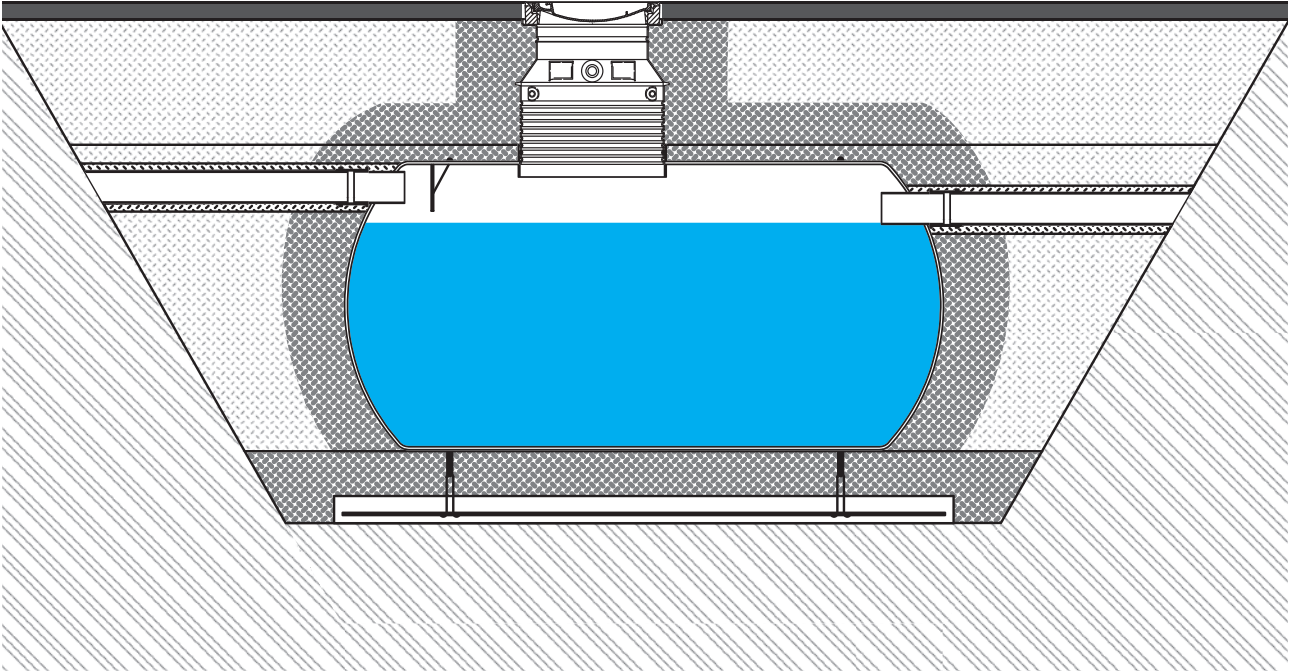

STRUCTURE - B 125 / D 400

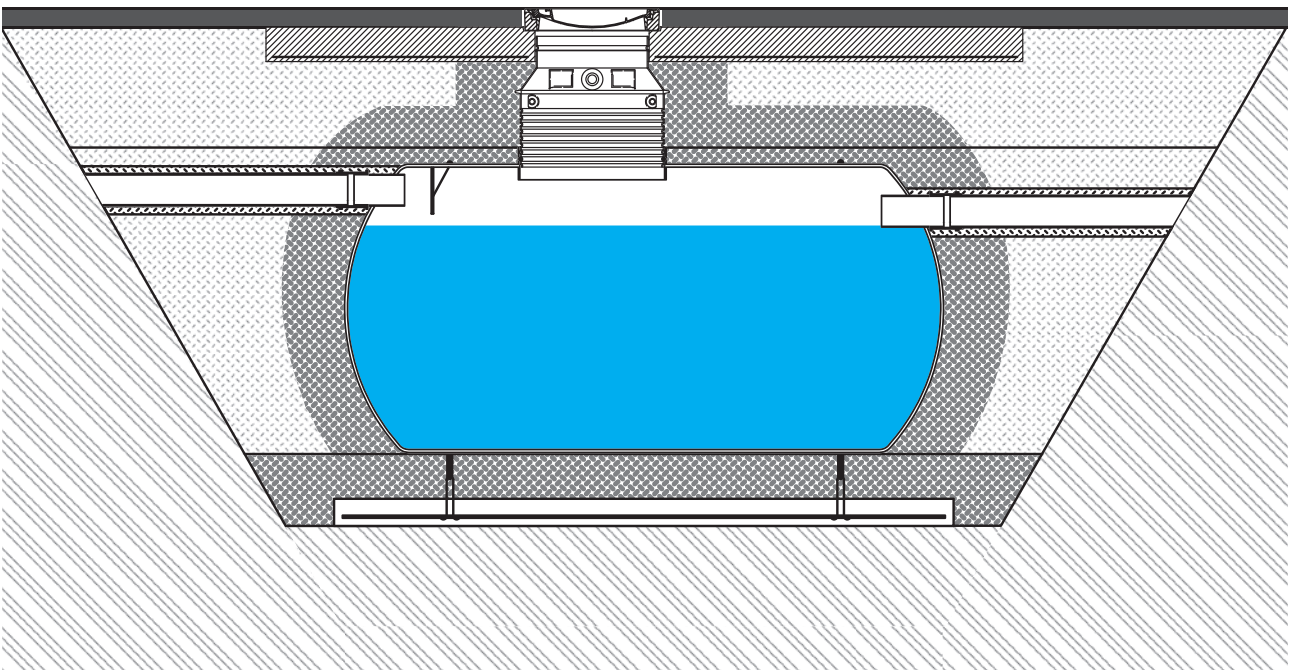

DIMENSIONS - A 15

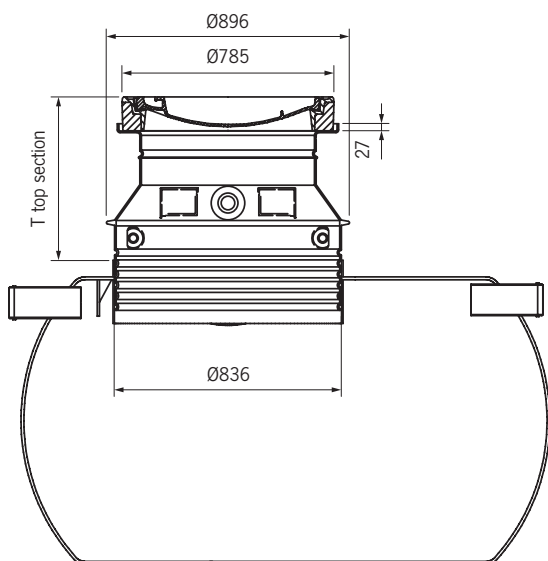

SIZE	A 15 - T top section	
	MIN	MAX
Short	520	640
Medium	520	1090
Long	520	1690

DIMENSIONS - B 125 / D 400

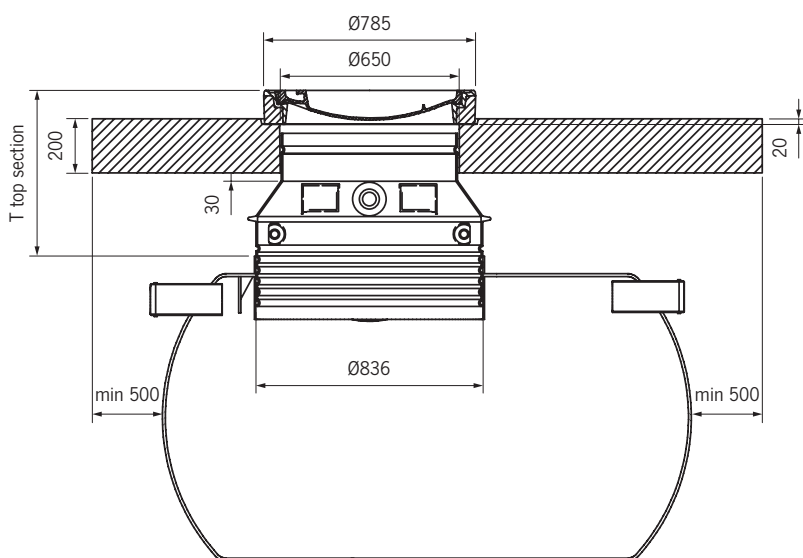









SIZE	B 125 - T top section	
	MIN	MAX
Short	550	670
Medium	550	1120
Long	550	1720

SIZE	D 400 - T top section	
	MIN	MAX
Short	550	680
Medium	550	1130
Long	550	1730



LEGEND

LEGEND - LAYERS	
	Soil
	Compacted soil
	Gravel 2 - 8 mm
	Gravel 8 - 16 mm
	Sand
	Water
	Final surface

SAND / GRAVEL 8-16 mm			
Table CE/3 Packing Tool	Layer Thickness	Passes / Layers	
	Hand stamp min. 15 kg	150 mm	4
	Vibrator stamp 70 kg	300 mm	4
	Vibrator flat 100 kg	150 mm	6

TANK INSTALLATION

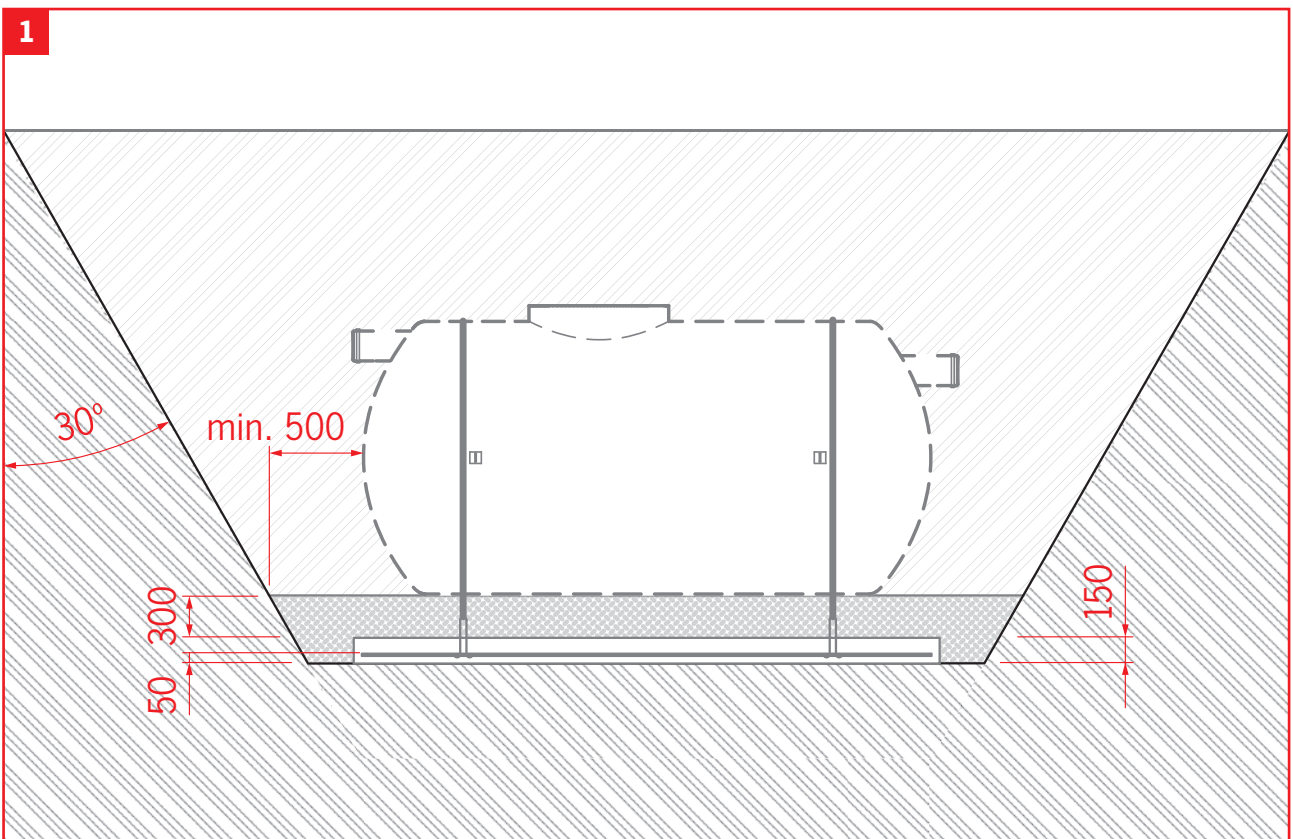

TANK INSTALLATION

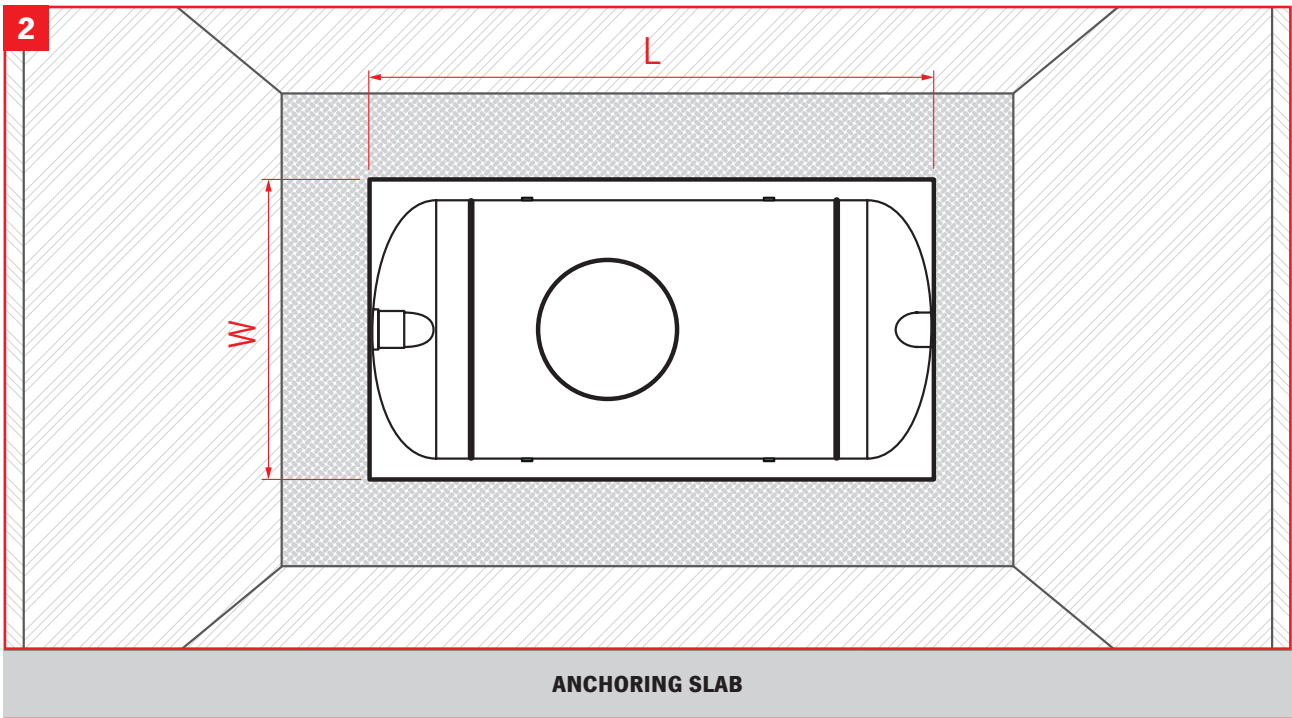

Concrete K 30-2	Concrete reinforcement A500 HW T10 K150,1 pcs. T10 around the edge, T10 SS lugs for anchoring straps.	Dimensions according to separator: W = Separator width + 200 mm L = Separator length, Thickness 150 mm
------------------------	--	---

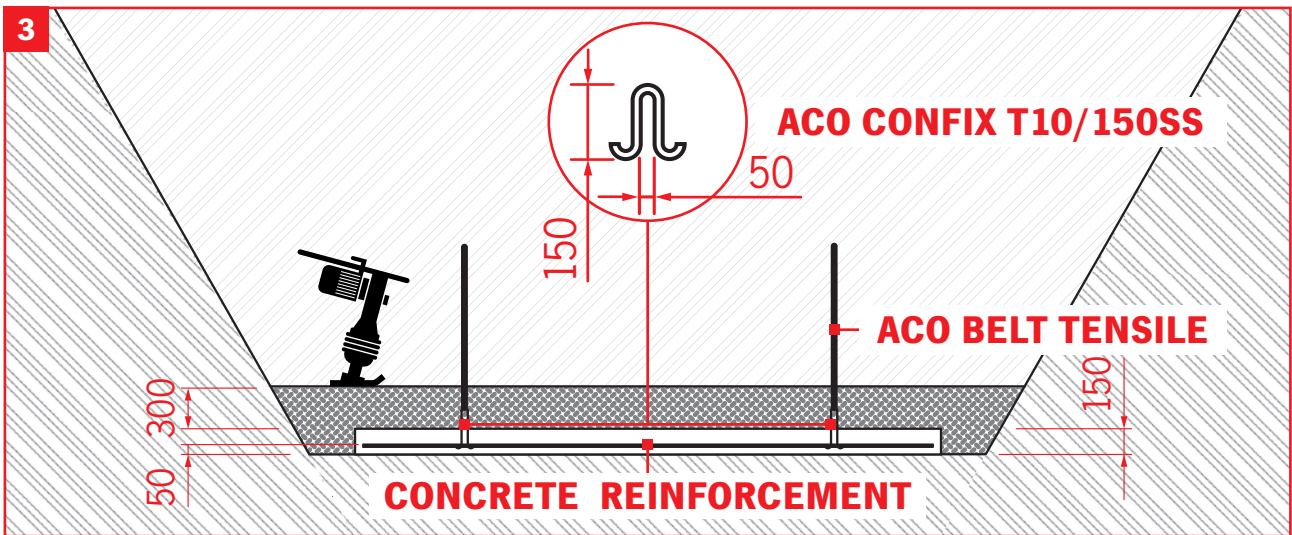

ACO SLUDGE TRAP G-H	ACO BELT TENSILE	ACO CONFIX / PCS
3000	2	4
6500	2	4
10000	3	6
15000	4	8
20000	5	10
30000	7	14
40000	10	20
50000	12	24
70000	20	40



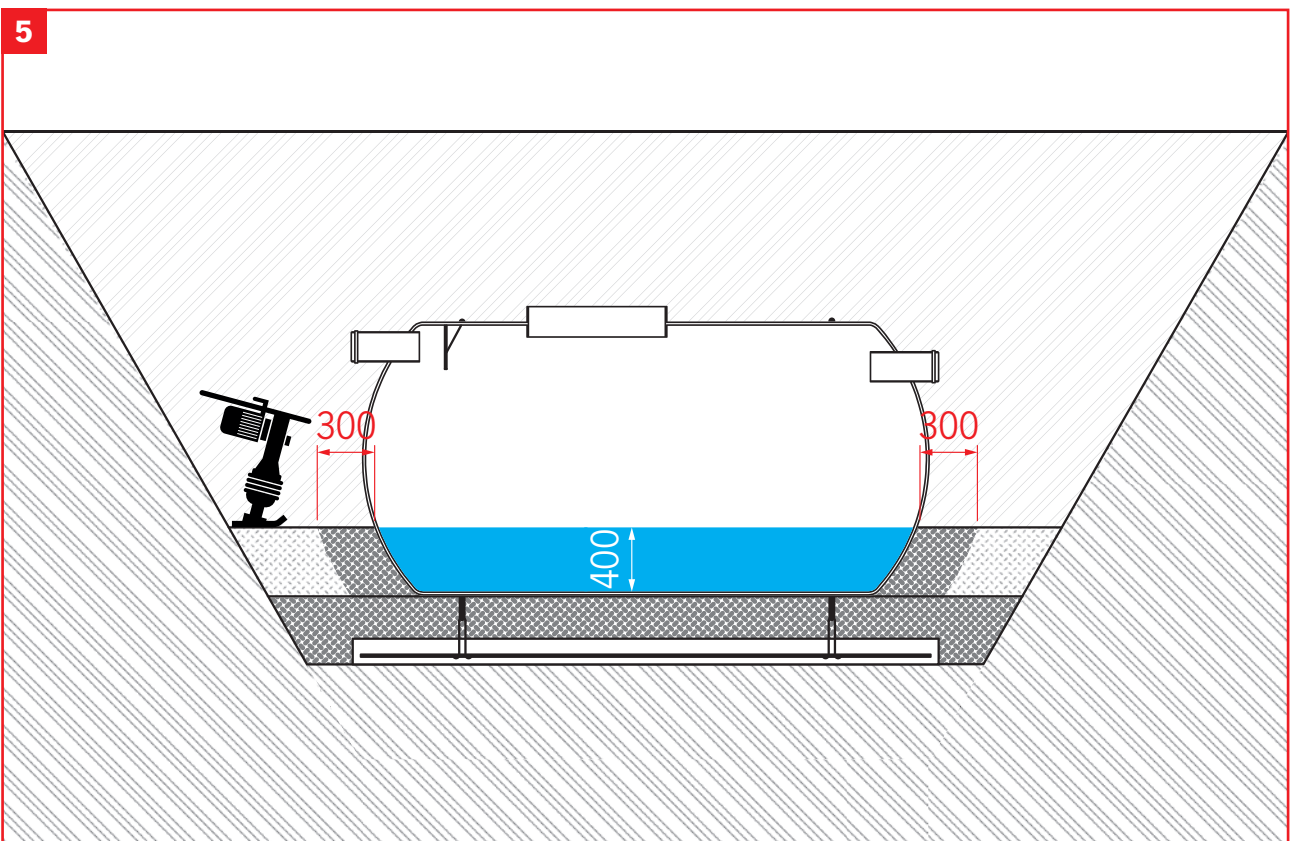
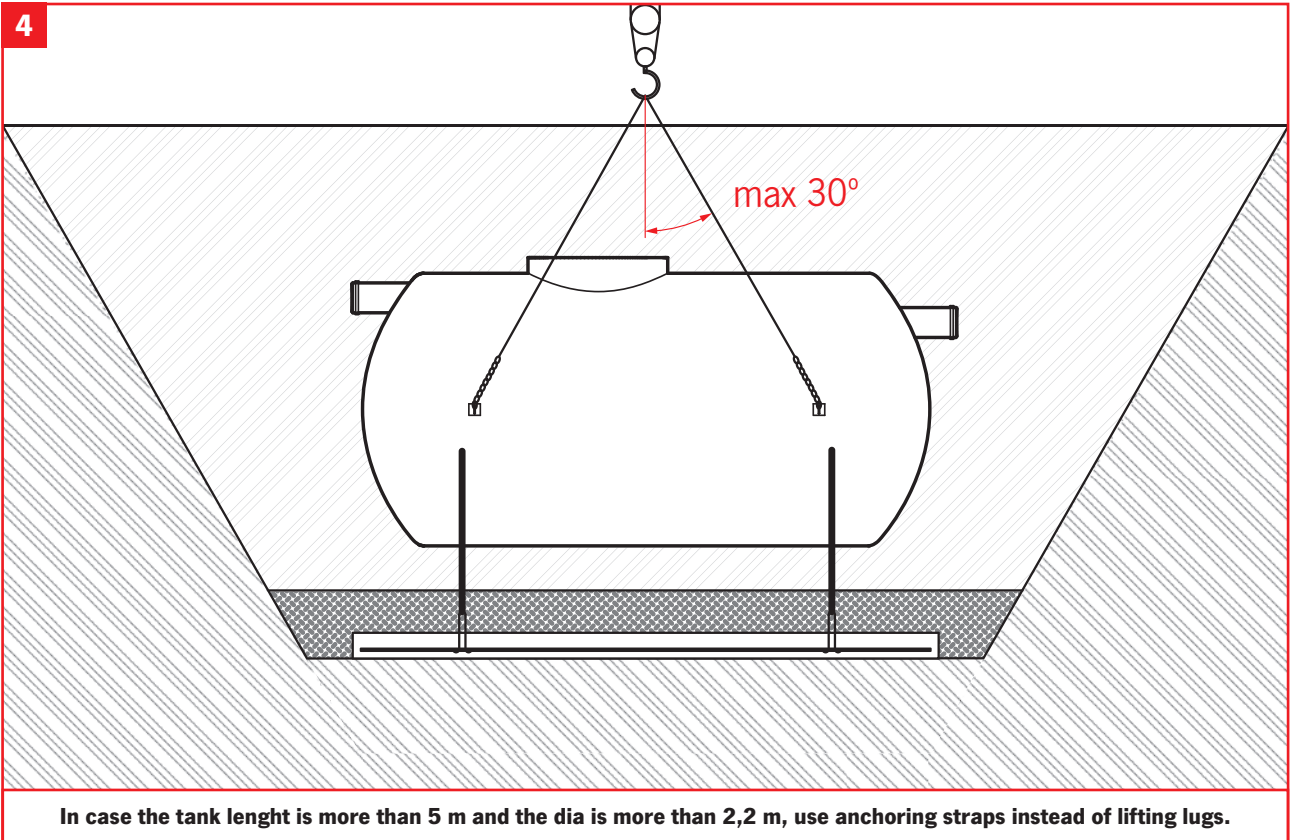

TANK INSTALLATION

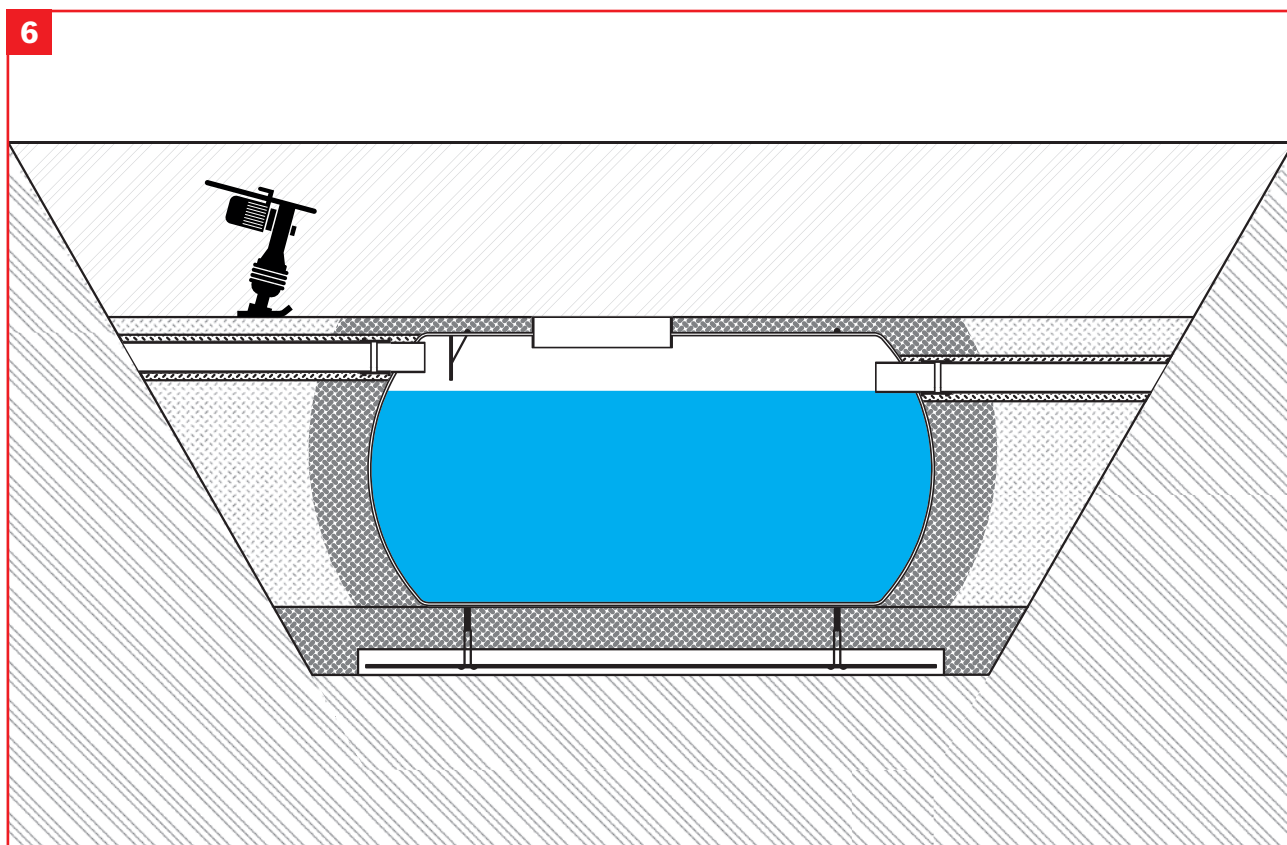

TOP SECTION INSTALLATION

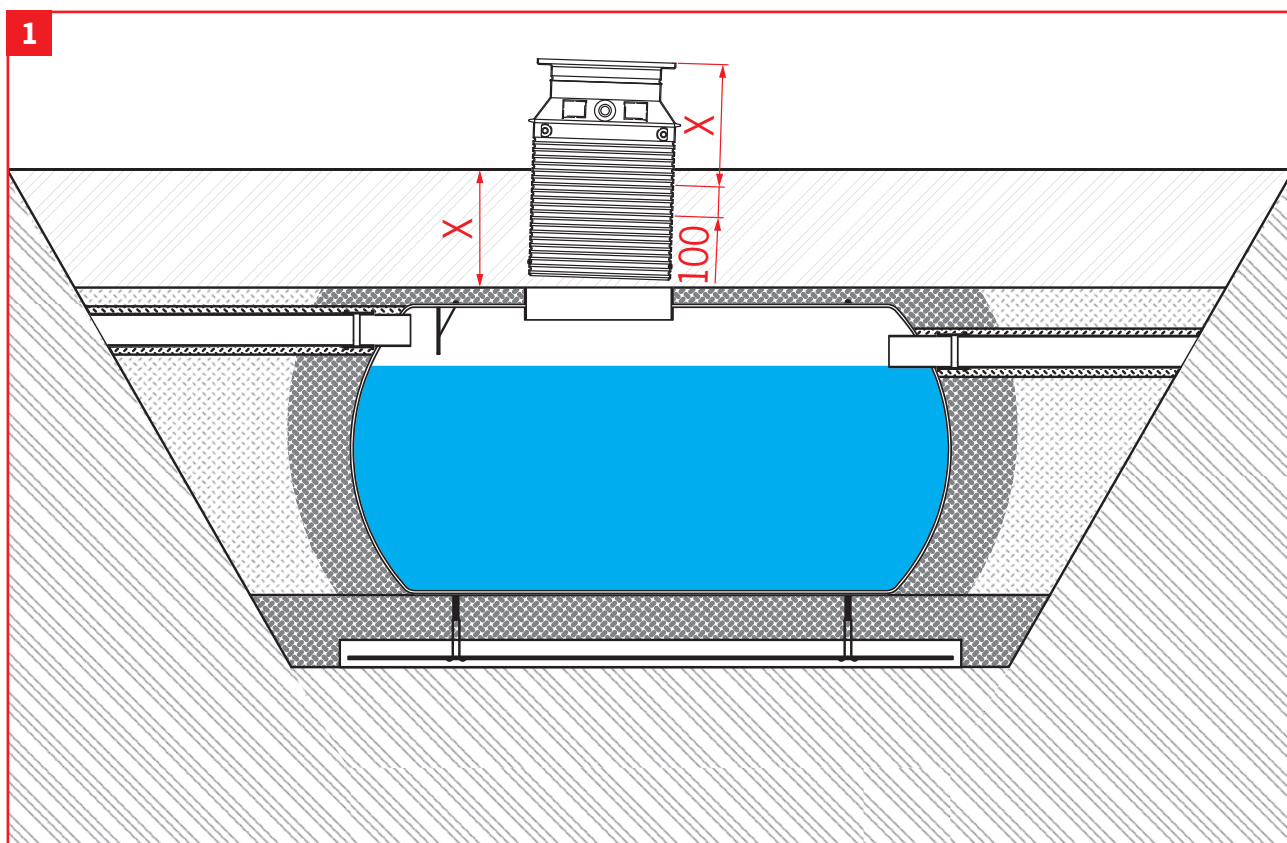

TOP SECTION INSTALLATION

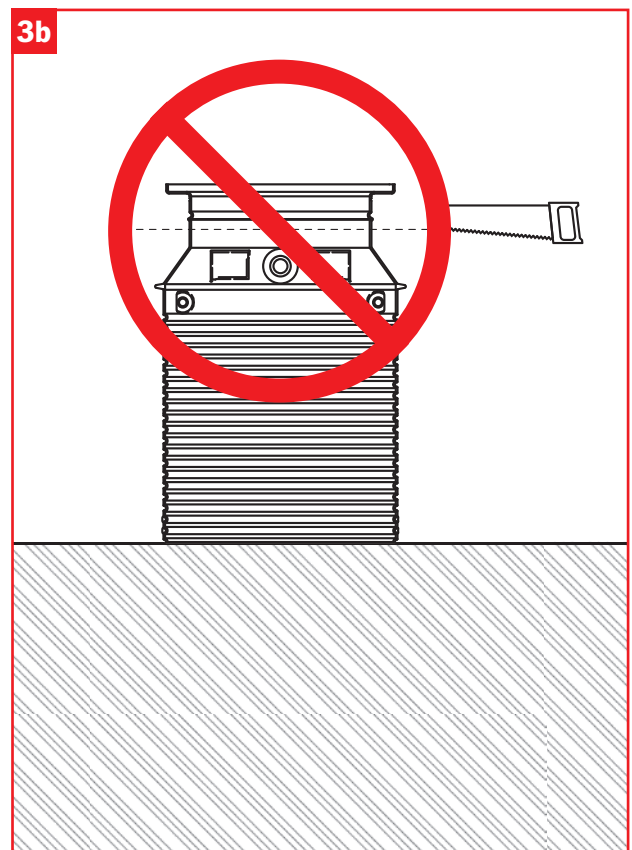
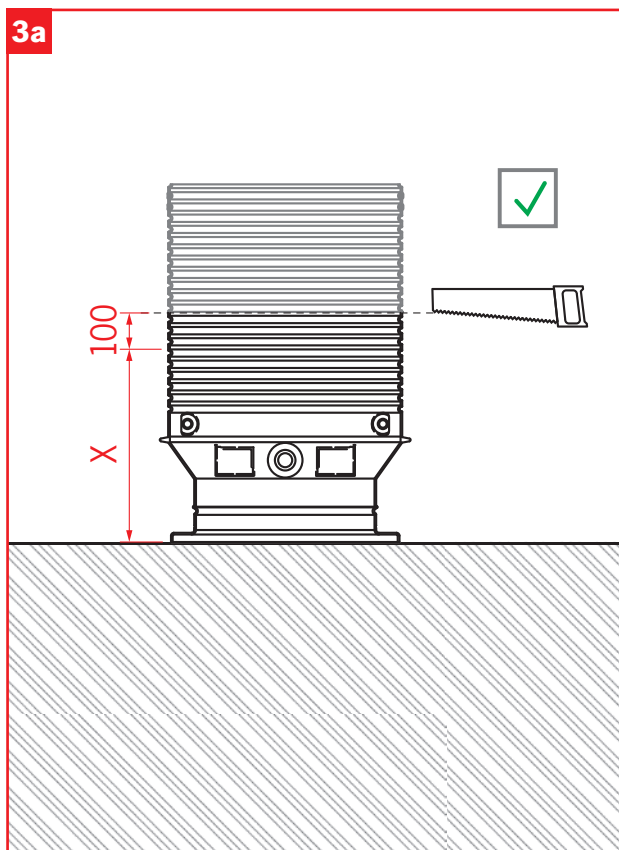
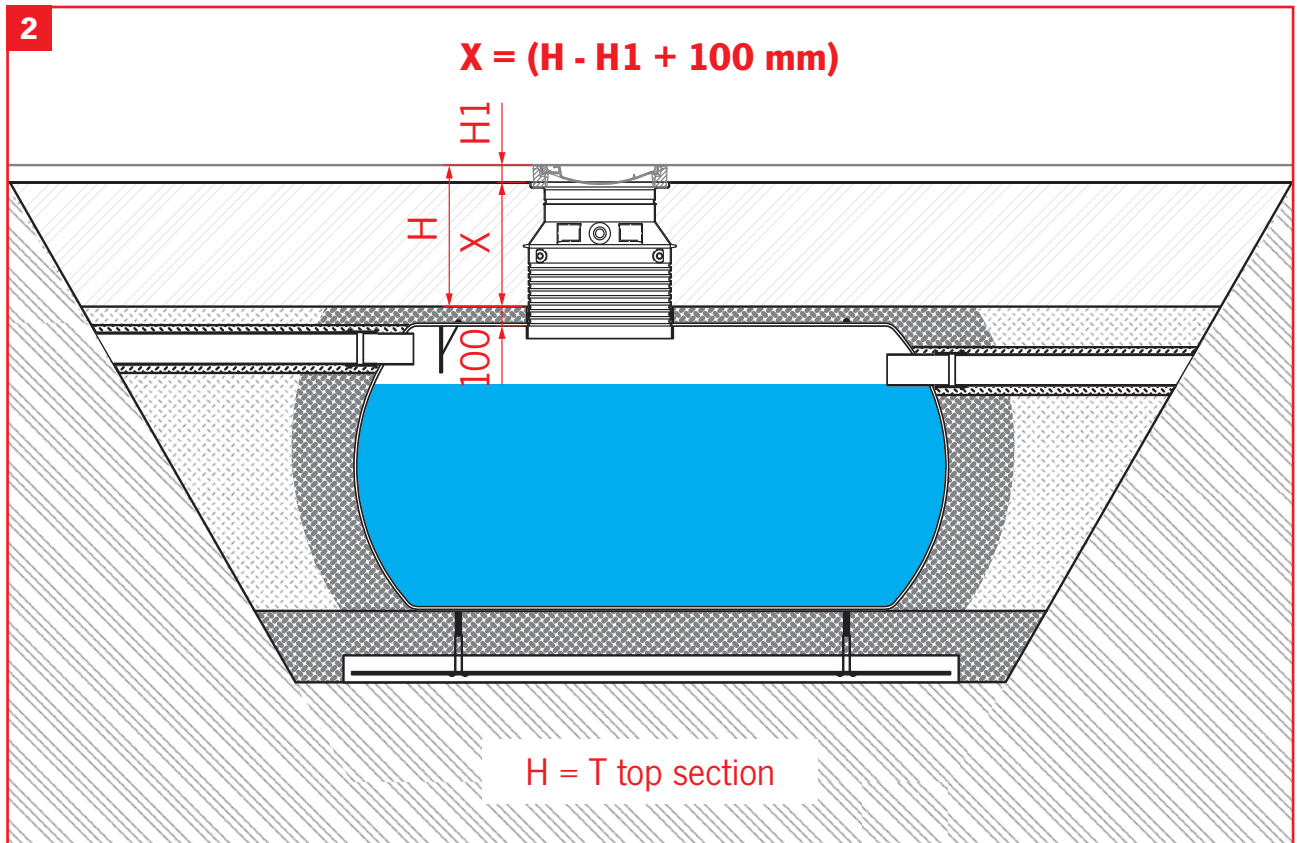

ALARM CONNECTION

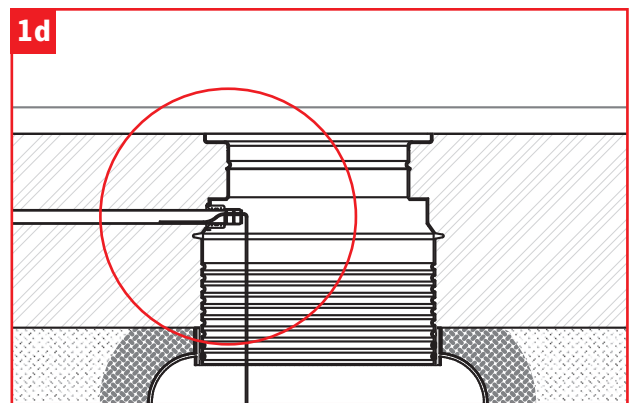
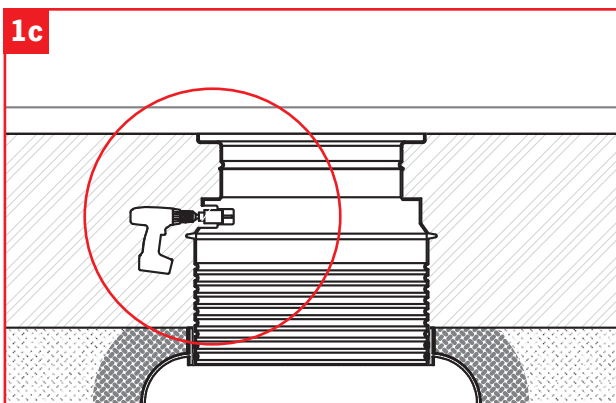
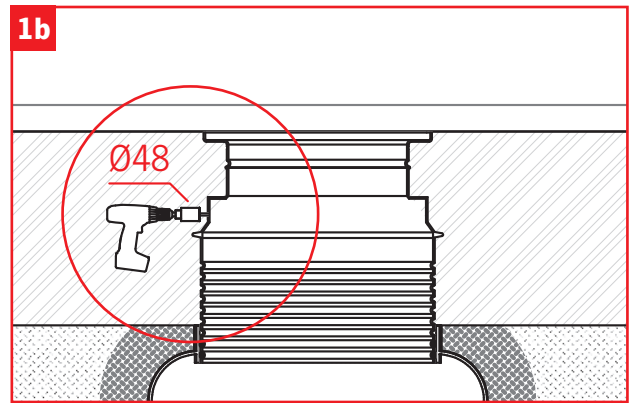
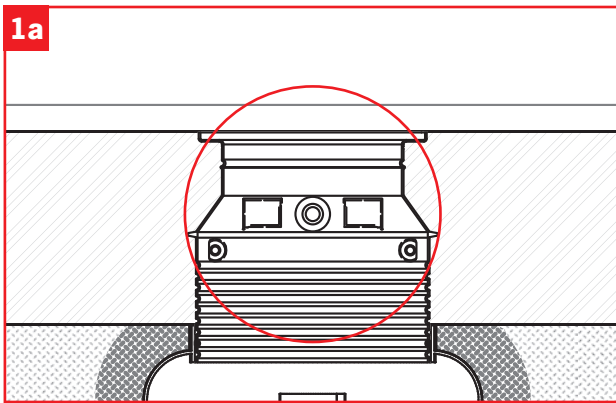

TOP SECTION INSTALLATION FOR LOAD CLASS - A 15

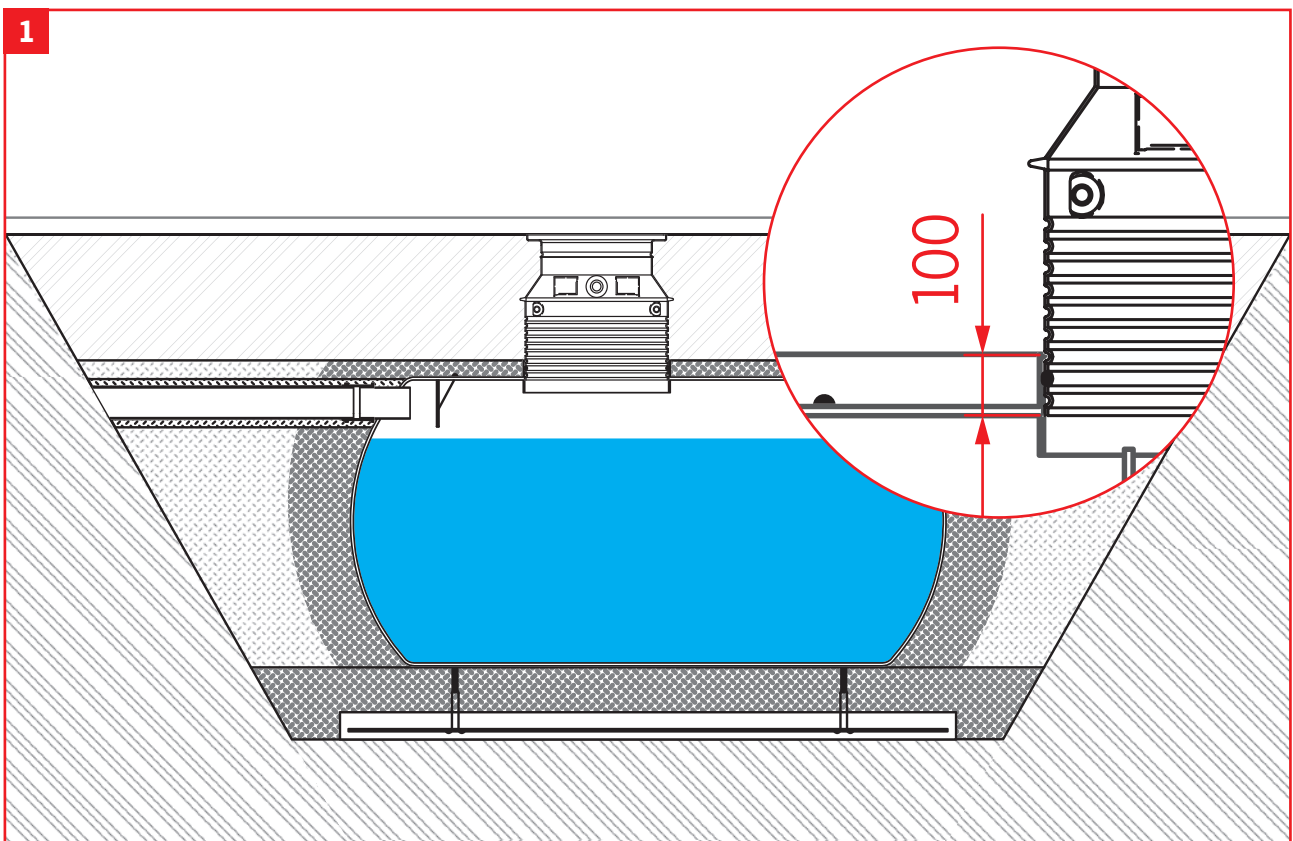

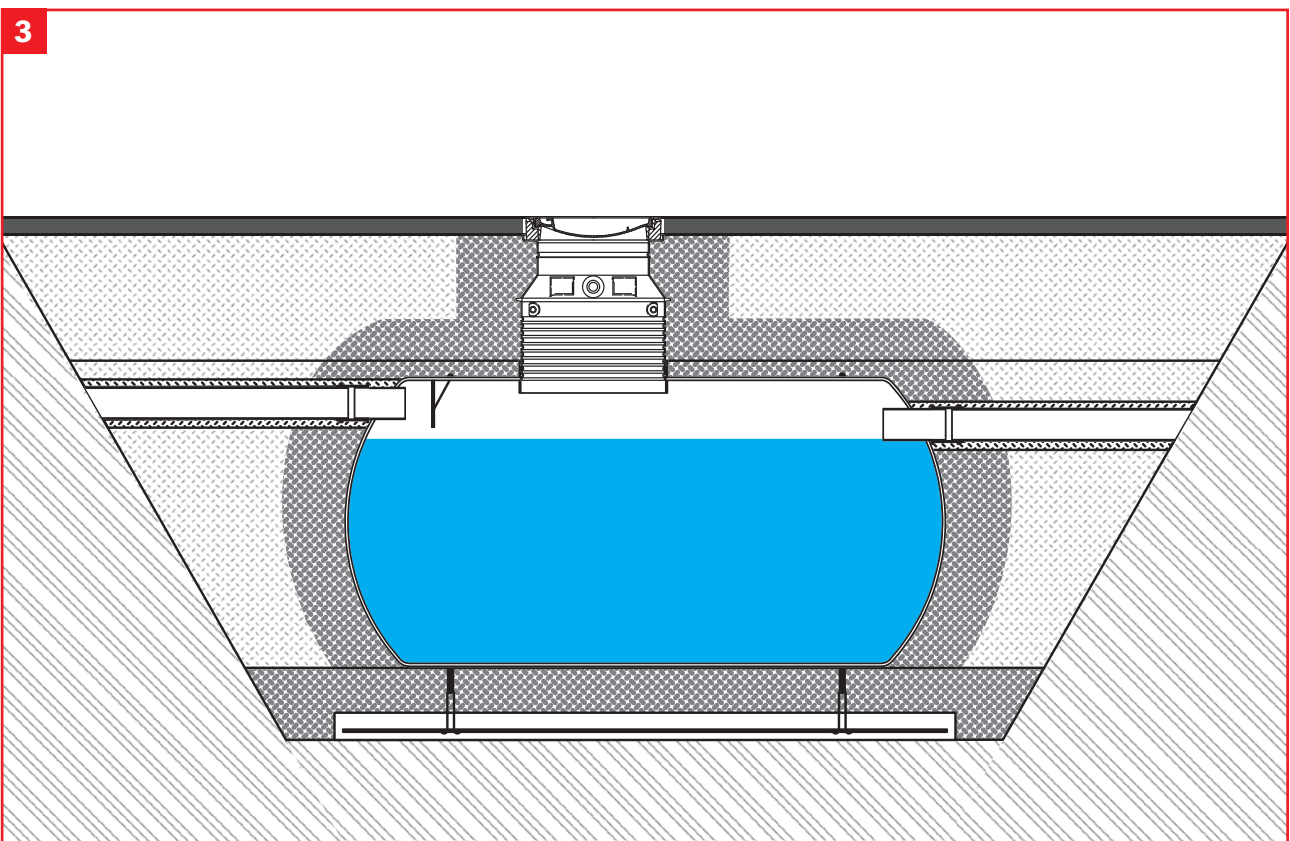
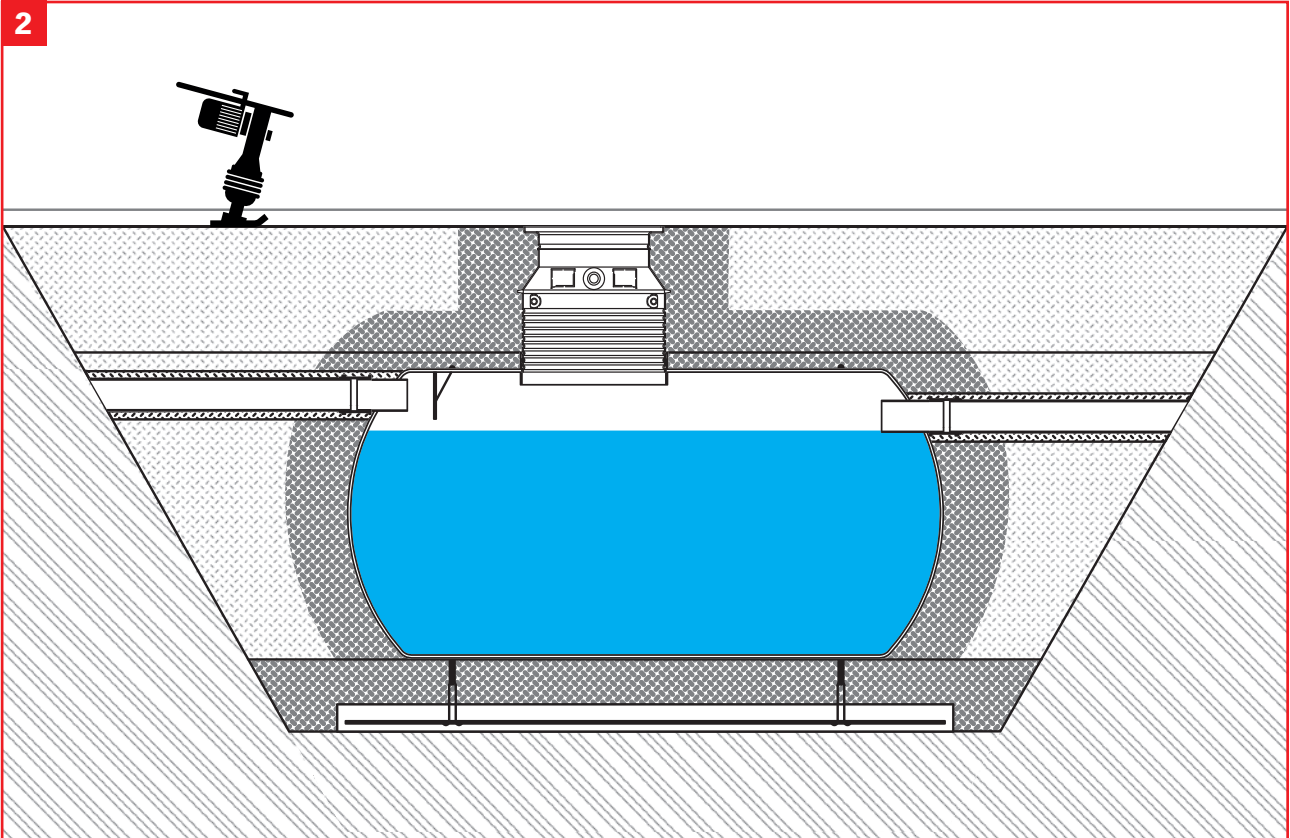

TOP SECTION INSTALLATION FOR LOAD CLASS - B 125 / D 400

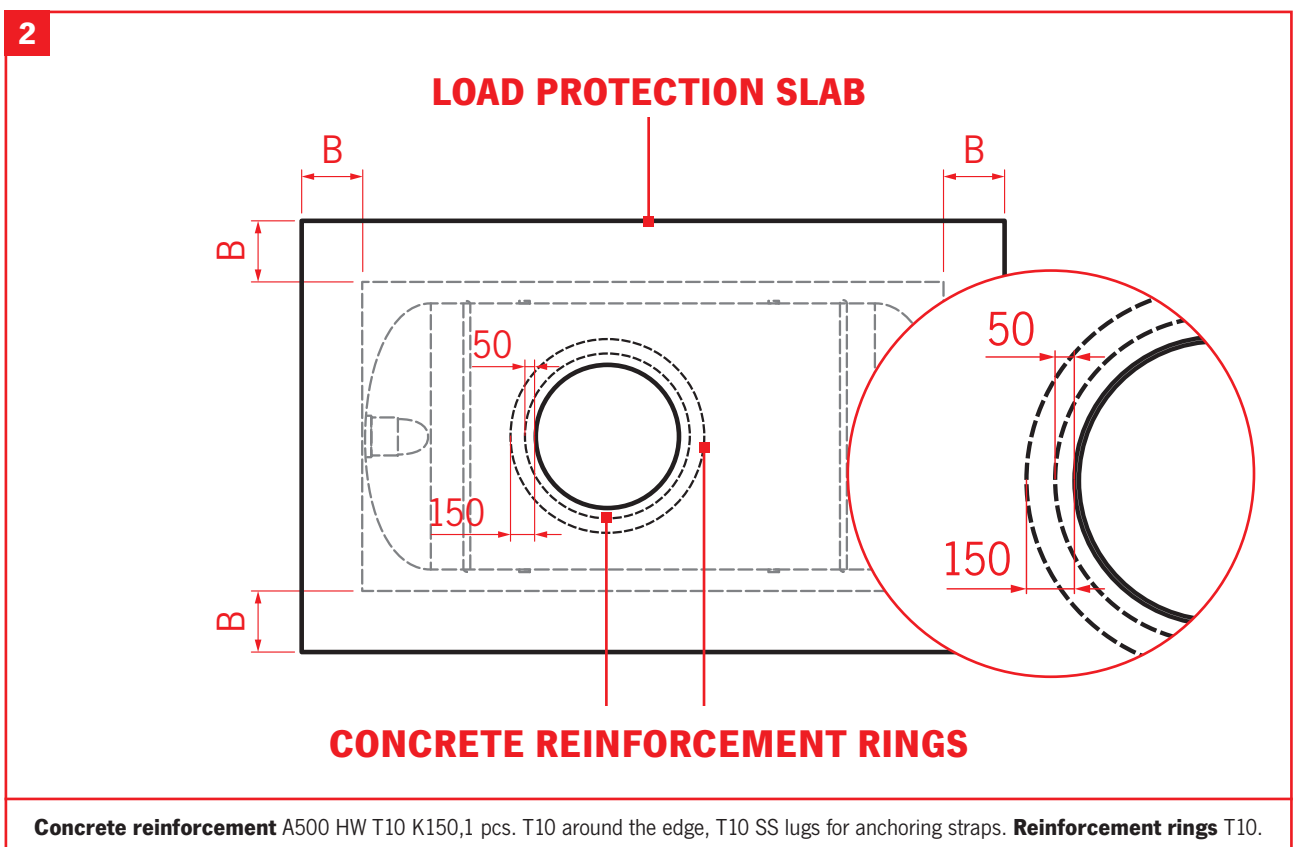
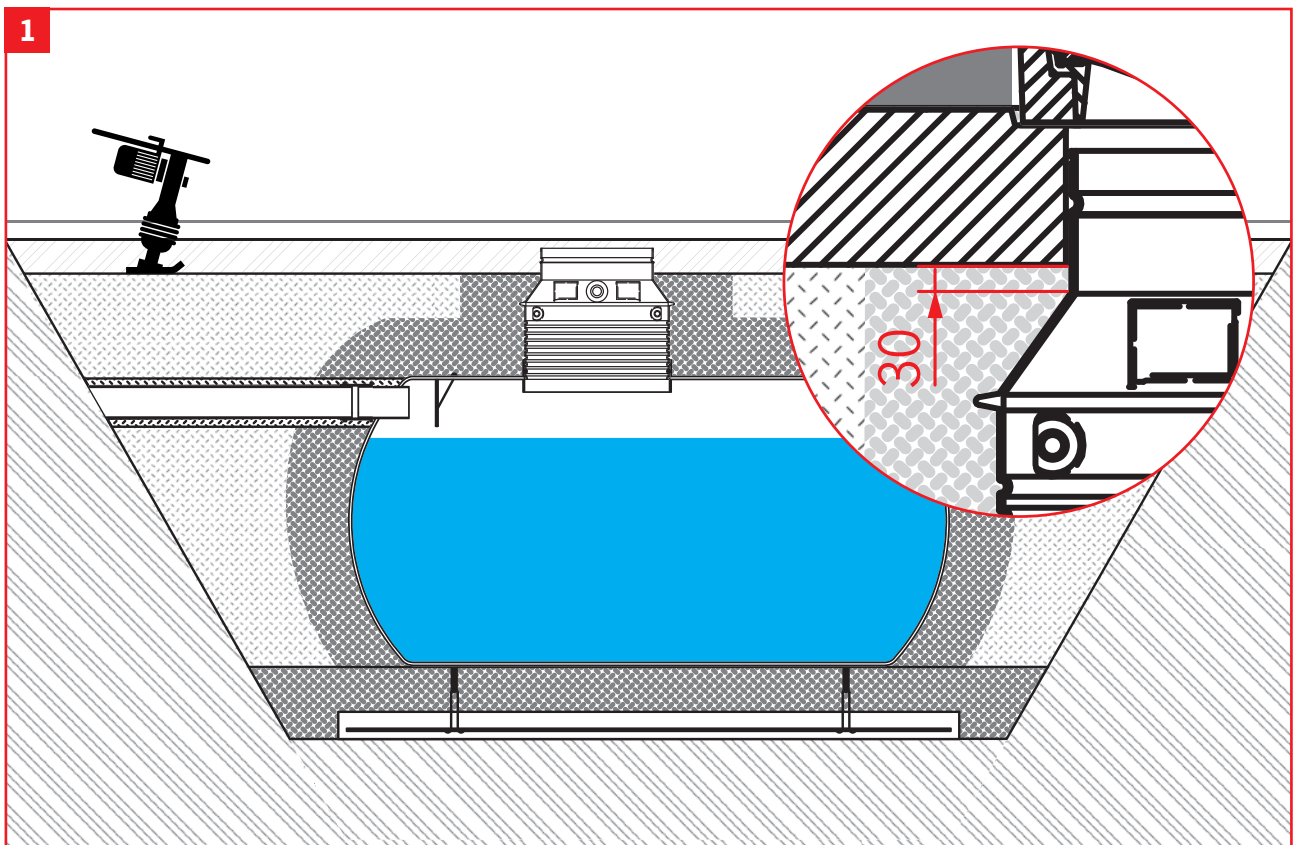

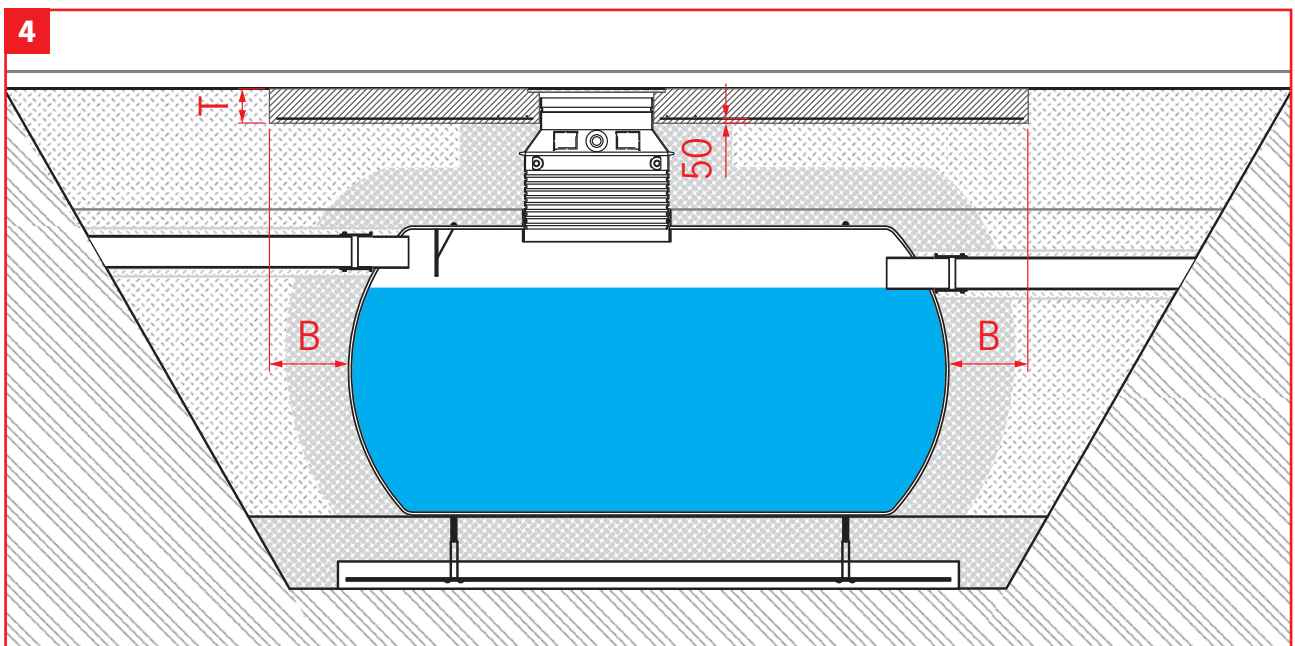
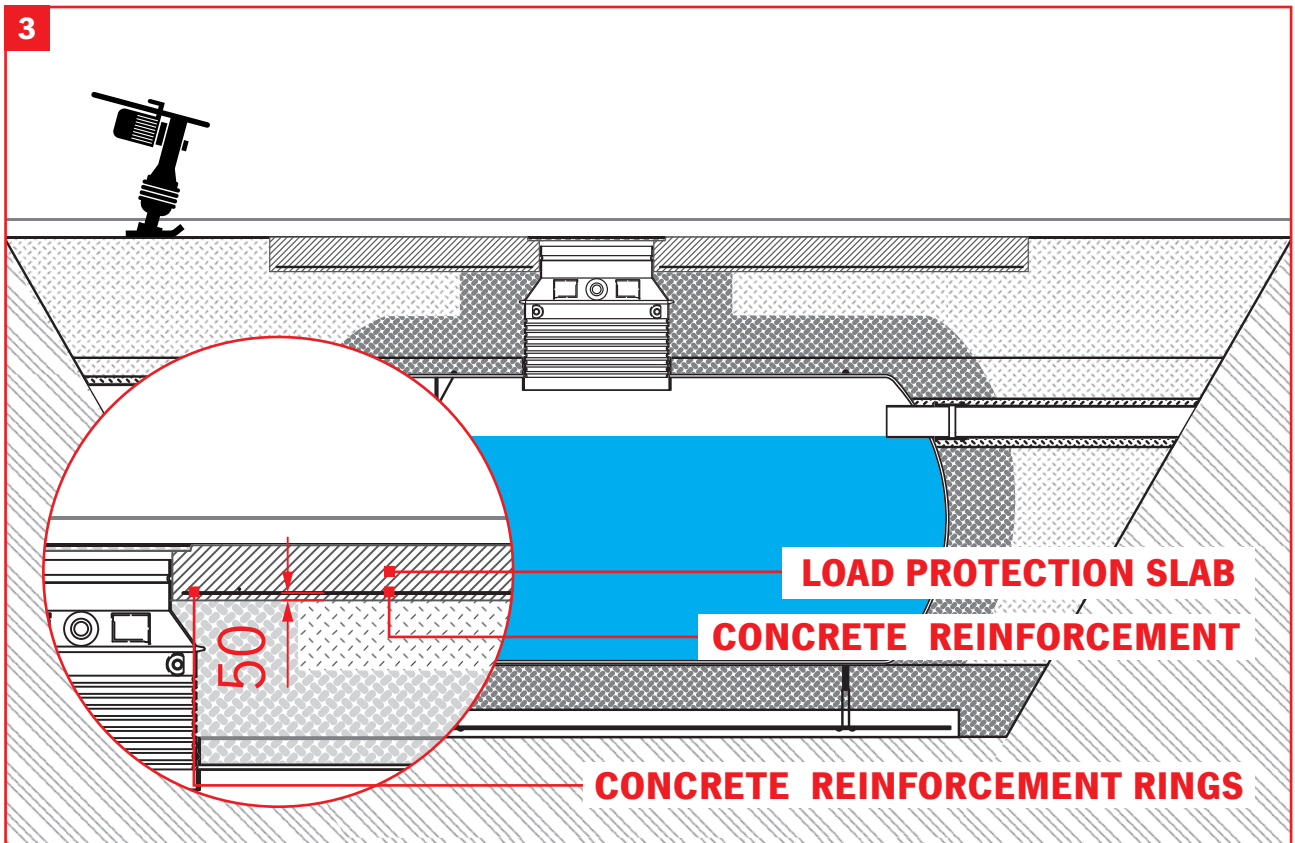

LOAD PROTECTION SLAB

DIAMETER [mm]	T [mm]	B [mm]
≤ 1200	200	500
≤ 1800	250	500
≤ 2600	280	500
≤ 3000	300	500



TOP SECTION INSTALLATION FOR LOAD CLASS - B 125 / D 400

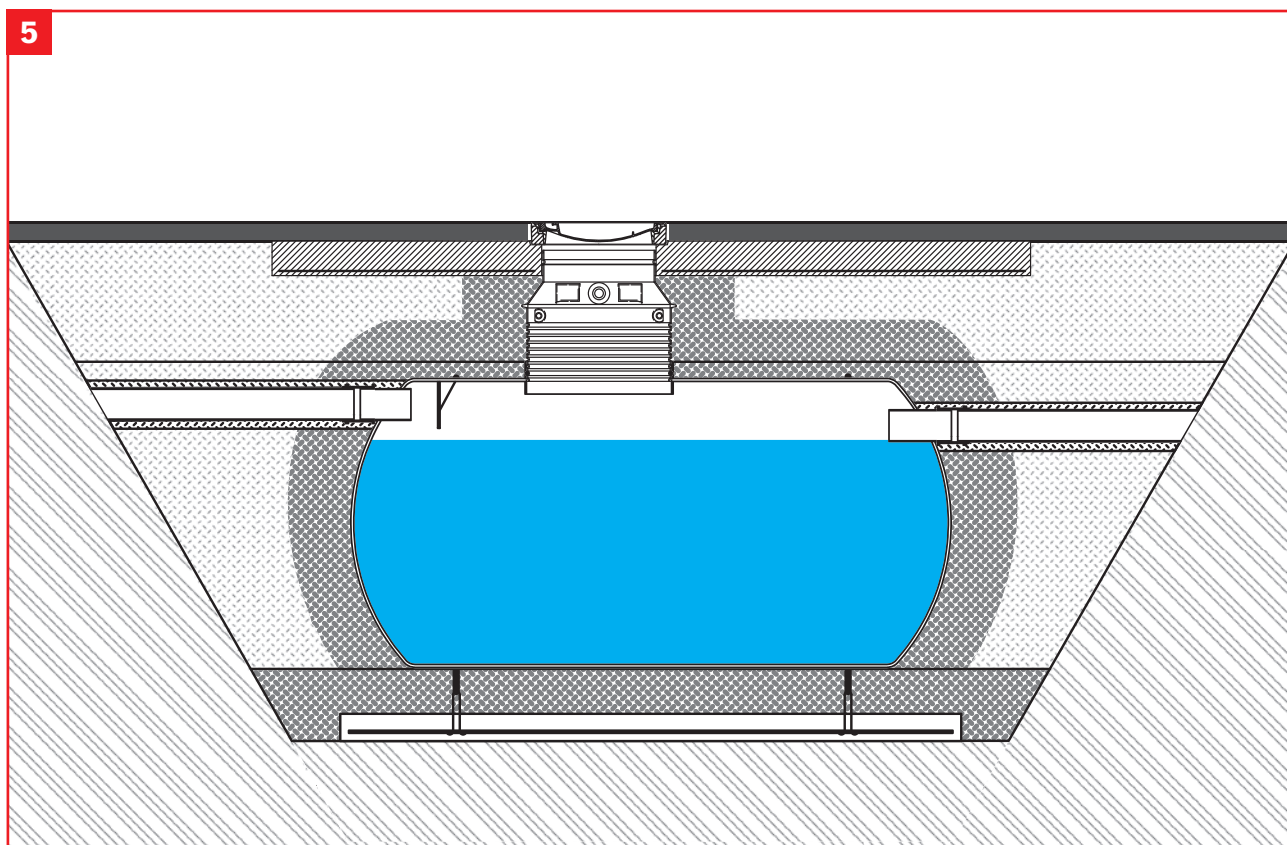

DESIGNATION LABEL

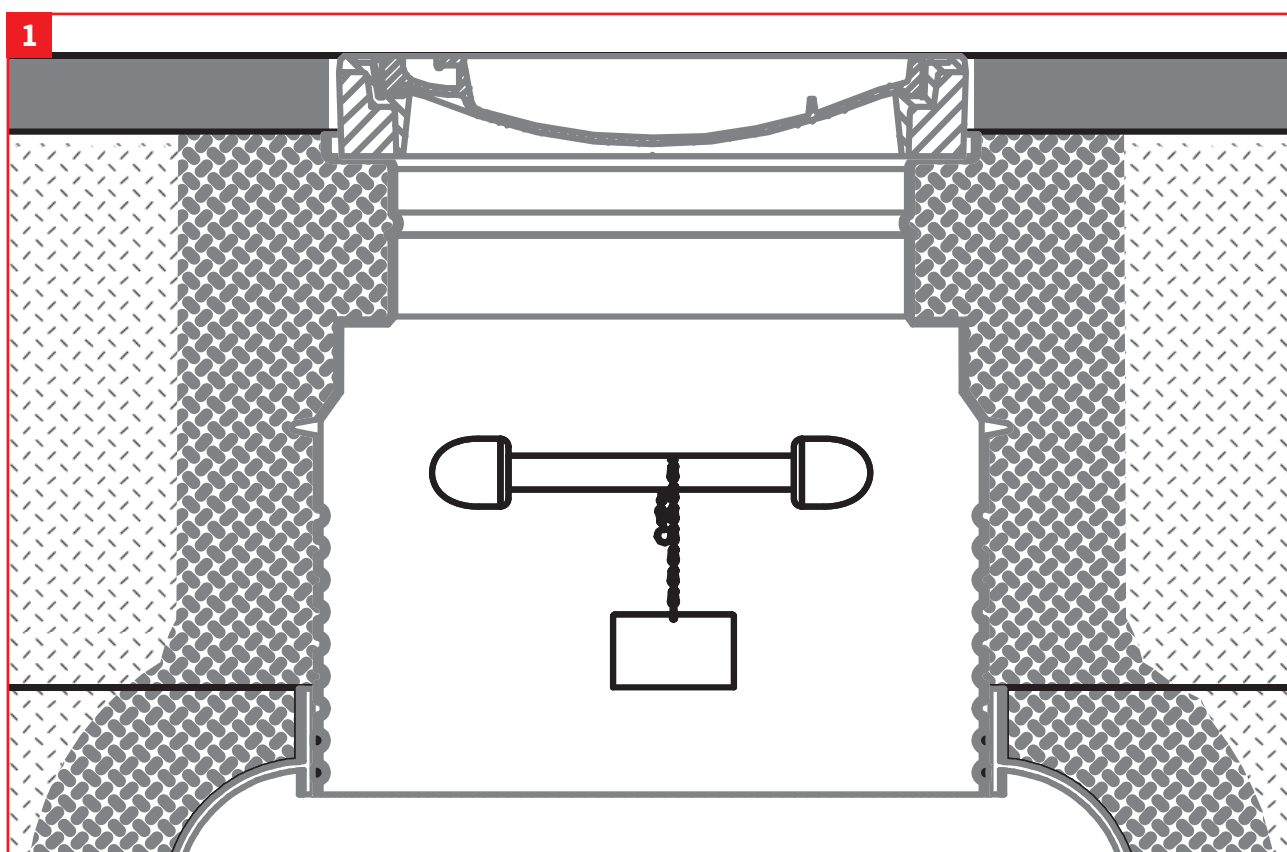

NOTES

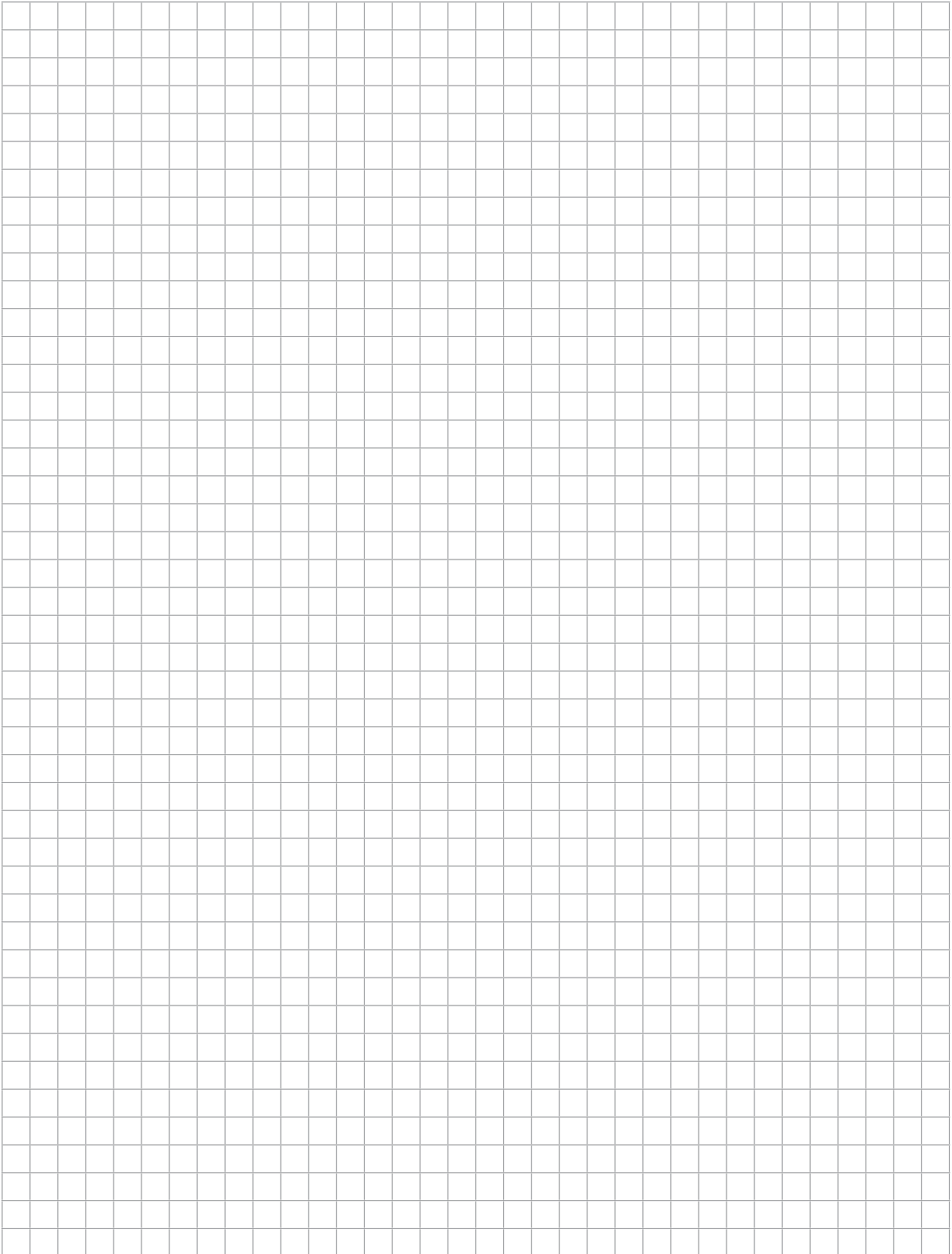

Final surface



Water



Sand



Gravel 8 - 16 mm



Gravel 2 - 8 mm



Compacted soil



Soil



NOTES



ACO Industries Tábor s.r.o.

Prumyslova 1158
391 01 Sezimovo Usti
Czech Republic

www.aco.com

ACO. The future of drainage

All reasonable care has been taken in compiling the information in this document. All recommendations and suggestions on the use of ACO products are made without guarantee since the conditions of use are beyond the control of the Company. It is the customer's responsibility to ensure that each product is fit for its intended purpose and that the actual conditions of use are suitable. This brochure and any advice is provided free of charge and accordingly on terms that no liability (including liability for negligence) will attach the Company or its servants or agents arising out of or in connection with or in relation to this brochure or any such advice. Any goods supplied by the Company will be supplied solely upon its standard conditions of sale, copies of which are available on request. The Company's policy of continuous product development and improvement renders specifications liable to modification. Information provided in this brochure is therefore subject to change without prior notification.